

The Apollo

Our **Apollo** water treatment system uses Copper Silver Ionisation technology to control bacteria in your water system. It ensures continuous dosing of Copper and Silver ions with a 10:1 ratio of Copper and Silver Ions (minimum silver ion ratio given).

The **Apollo** measures water flow with high precision, using non-mechanical ultrasonic sensing technology to detect flow.

The system is designed for easy maintenance, with flow cells that minimize scale deposition, electrodes designed to last, and optional Ethernet connectivity for remote data capture and control functionality.

Hydrotec guarantees electrode purity of greater than 99%, providing a cost-effective and safe water treatment solution.

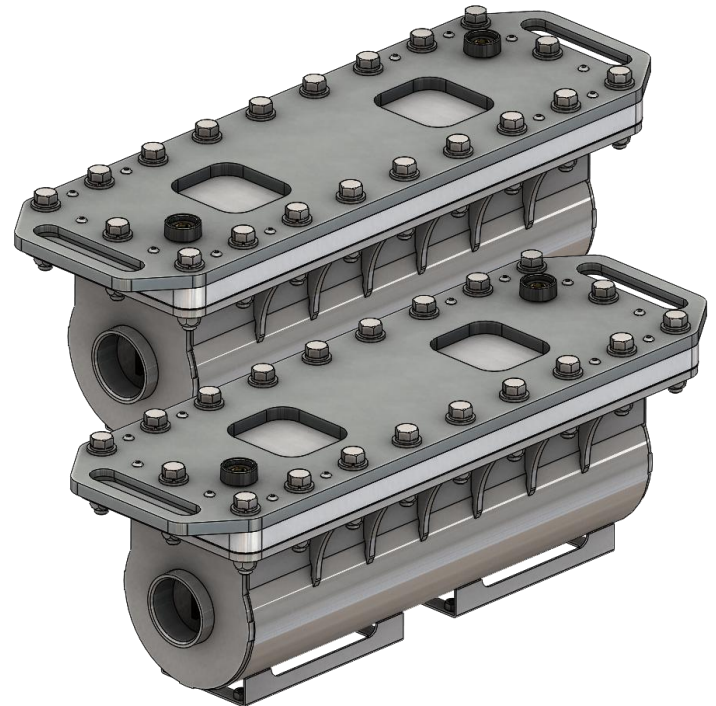

Copper Silver Ionisation

Copper-Silver Ionisation is a disinfection method for drinking water, it utilizes copper and silver ions to control microorganisms. By passing an electric current through electrodes, ions disperse into the water, targeting and damaging microbial cellular structures.

This process effectively inhibits growth and reproduction of bacteria, algae, and pathogenic organisms. It serves as an effective alternative to liquid chemical disinfection technologies.

Copper-Silver Ionisation combats Legionella and other pathogens without creating harmful by-products, ensuring high-quality drinking water.

Key Benefits

- Controls bacteria in your water system
- Achieves high accuracy dosing with no mechanical parts
- Easy to install and operate
- Minimizes electrode wear and replacement costs
- Ensures consistent water quality for your system
- Protects pipes and water systems from corrosion and malfunction
- Minimal maintenance and easy consumable replacement

The Design

The Hydrotec Apollo Copper-Silver Ionisation Unit is an advanced water disinfection system, controlling harmful microorganisms in drinking water. Optimized for efficiency, safety, and reliability.

Featuring a user-friendly interface with a 4.3-inch touch screen display, the system allows operators to monitor and control the system, providing real-time information on the ionisation process. The advanced electrode chamber houses solid copper and silver electrodes, designed for easy access and maintenance, with removable electrode plates.

Equipped with an electronic controller, the unit regulates ion release, ensuring consistent and effective dosage of copper and silver ions for water disinfection. Designed for flexible installation and integration with existing water systems, the unit accommodates various pipe sizes and can be installed horizontally or vertically.

The unit comprises three main components: the pulsing water meter, controller, and a stainless-steel flow cell.

In summary, the Apollo Copper-Silver Ionisation Unit offers an advanced water disinfection solution, combining performance, ease of use, and seamless integration. The user-friendly interface, sophisticated electrode chamber, flexible installation options, and focus on safety make it a top choice for maintaining high-quality drinking water across various facilities.

Installation Notes

- The system must be frost-protected
- The installation site must be free from solvent, colorant, varnish and chemical vapours
- Flow directions at the input and output must be consistent with the heating/cooling circuit
- No tensile, pressure, and torsion forces can act at the input and output connections
- A single phase 240V mains connection should be provided to the unit controller
- Drainage should be available, for the filter's servicing
- Access should be available for servicing and maintenance
- The flow meter should be installed on a straight section of pipe, of the length of 15 times the pipe's outer diameter
- Technical data and technical guidelines should be followed per the O&M manual and local regulations

Installation Diagram

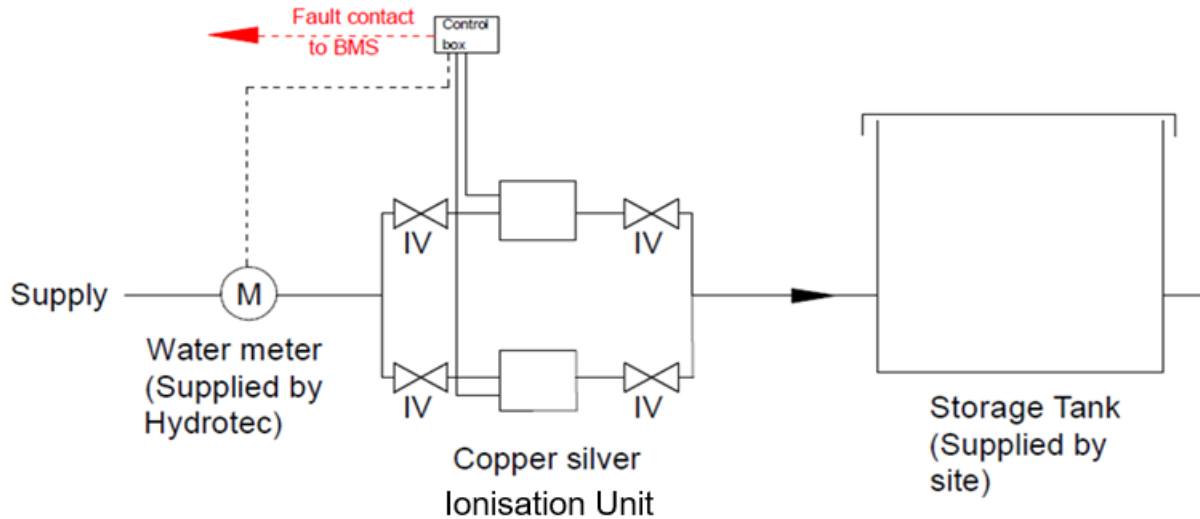

System Components

Flow Cell (x2)

1. Flow Cell Body
2. Gasket
3. Retaining Block
4. Flat Washer
5. Retaining Bolt
6. Retaining Nut



Control Unit

1. Input Screen & Display
2. Mains Power Connection, Switch & Fuse
3. Electrode Connection Points channel 1
4. Electrode Connection Points channel 2
5. Flow Meter Connection Point.

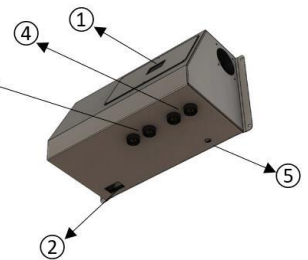

Water Meter Control Unit

1. LCD Menu/Display
2. Input Keyboard



Clamp on Flow Transducer

1. Flow Direction
2. Magnet
3. Model Number



Apollo LC16K Dual - Flowcell Specification	
Electrode Weight Per Flowcell	16 kg
Number of Flowcells	2
Electrode Total Weight	32 kg
Recommended Dosing Rate	0.2 to 0.8 ppm
Treated Water Volume at 0.44 ppm	72,720 m ³
Dimensions (H x W x D)	210mm x 215mm x 455mm per flowcell
Peak Flow Rate at 0.44ppm total ions, 250µS/cm inlet water conductivity	30 l/s in series 60 l/s in parallel
Pipe Connections	2" Female Threaded (Additional sizes & flanged options available)
Pressure Rating	12 bar
Temperature Rating	100°C
Number of Cu/Ag Plates Per Flowcell	8/1 per flowcell 400mm x 100mm x 5 mm
Copper Plates Composition	99.9% Pure Copper
Silver Plates Composition	99.9% Pure Silver
Construction	316L Stainless Steel
Regulatory Approval	WRAS, UK Biocidal Product Regulations, EU Biocidal Product Regulations, US EPA Approval
Control Box Specification	
Control Box Type	Programmable or Smart
Construction	316L Stainless Steel
Supply Voltage	110-230V Switchable, 50/60Hz
Dimensions (H x W x D)	340mm x 225mm x 250mm
Power Consumption	1,000 W max
Programmability	Ionisation and Flow Rate
Data Logging (option with Smart Controller)	Flow Rate and Current Consumption

Technical Specification:

For the control of bacteria in a water system the mechanical installation specialist shall install a copper silver ionisation system.

The system shall comprise of a single stainless-steel flow cell capable of achieving the full peak design flow rate.

Cu/Ag dosage shall be proportionally controlled using a non-intrusive ultrasonic water meter.

This design has been based on the Apollo LC16K Dual copper silver ionisation system as supplied by Hydrotec, but shall generally be in accordance with the schedule:

- Electrode Weight Per Cell: 16kg
- Inlet/Outlet Connections: 2"
- Target Dosing Rate: 0.44 ppm total metal ions
- Approximate Electrode Lifespan (m³): 2,270 @ 0.44ppm total metal ions
- Copper Silver ratio must be 10:1 copper:silver

The unit must comprise the following features:

- Electrode Purity must be greater than 99%.
- Unit must be WRAS approved.
- Dosing rate to allow for minimum Copper level of 0.4 mg/l and 0.04 mg/l of Silver following the unit.
- Fully compliant with IEC 1201 which limits in terms of voltage applied to water or wet environments to a maximum of 35 Volts DC.
- Flow cells shall be designed to minimise scale deposition and promote laminar water flow. Control units shall be designed to minimise scale deposition and at minimum ensure reversal of anode polarity at regular intervals.
- Rectangular shaped electrodes must be used.
- Flow cell to be manufactured from 316 Grade Stainless Steel.
- Flow cells are ideally located horizontally and at a safe working height to permit maintenance.
- Dosing shall be performed only from on the full incoming supply and side stream dosing or measurement shall not be deemed suitable.